

AN ORDINANCE DIRECTING THE CITY TRAFFIC ENGINEER  
TO CAUSE THE PLACEMENT OF CERTAIN TRAFFIC CONTROL DEVICES  
AT THE INTERSECTIONS OF  
FLORIDA AVENUE WITH RACE AND VINE STREETS

WHEREAS, Section 2-1(b) of the Urbana Local Traffic Ordinance, as amended, provides that it shall be the general duty of the City Traffic Engineer to determine the installation and proper timing of traffic control devices; and

WHEREAS, Section 4-1 of the Urbana Local Traffic Ordinance, as amended, further directs the City Traffic Engineer to cause to be placed traffic control devices when and as required under the Traffic Ordinances of this City to make effective the provisions of said Ordinances; and

WHEREAS, the City Council now desires to direct the City Traffic Engineer to cause the placement of certain traffic control devices at the intersections of Florida Avenue with Race and Vine Streets without abrogating, diluting, amending, rescinding, or repealing the powers and duties of the City Traffic Engineer as otherwise provided by the Urbana Local Traffic Ordinance, as amended.

NOW, THEREFORE, BE IT ORDAINED by the City Council of the City of Urbana, Illinois, as follows:

SECTION 1. That the City Traffic Engineer be and the same is hereby directed to cause the placement of appropriate vehicle lane striping in accordance with the two (2) diagrams, which are attached hereto and hereby incorporated by reference, for the intersections of Florida Avenue with Race and Vine Streets.

SECTION 2. That the City Traffic Engineer be and the same is hereby directed to cause the retention of the placement of stop signs, as opposed to traffic control signals, for the intersections of Florida Avenue with Race and Vine Streets.

SECTION 3. That nothing contained in this Ordinance shall be construed to dilute, abrogate, amend, repeal or rescind the powers and duties of the City Traffic Engineer with respect to the lawful exercise thereof in connection with any and all other intersections or other traffic conditions in the City of Urbana.

This Ordinance is hereby passed by the affirmative vote, the "ayes" and "nays" being called of a majority of the Members of the Council of the City of Urbana, Illinois, at a regular meeting of said Council on the 19th day of September, 1977.

PASSED by the City Council this 19th day of September, 1977.

---

Duane Eckerty, City Clerk

APPROVED by the Mayor this \_\_\_\_\_ day of \_\_\_\_\_, 1977.

---

Jeffrey T. Markland, Mayor

*This ordinance was vetoed by Mayor. Council overrode veto at 10/3/77 meeting & ordinance became effective.*

7778-24

THIS IS THE ATTACHMENT WHICH IS REFERRED TO IN  
ORDINANCE NO. 7778-24 AND IS INCORPORATED  
THEREIN BY REFERENCE.

Ruth S. Brookens, City Clerk

Date

AF 7/78-24

FIGURE 2

# FLORIDA & RACE

EXISTING PAVEMENT WITH NEW LANE CONFIGURATION AND SIGNALS

SCALE: 1"=20'  
LANE LENGTH NOT TO SCALE

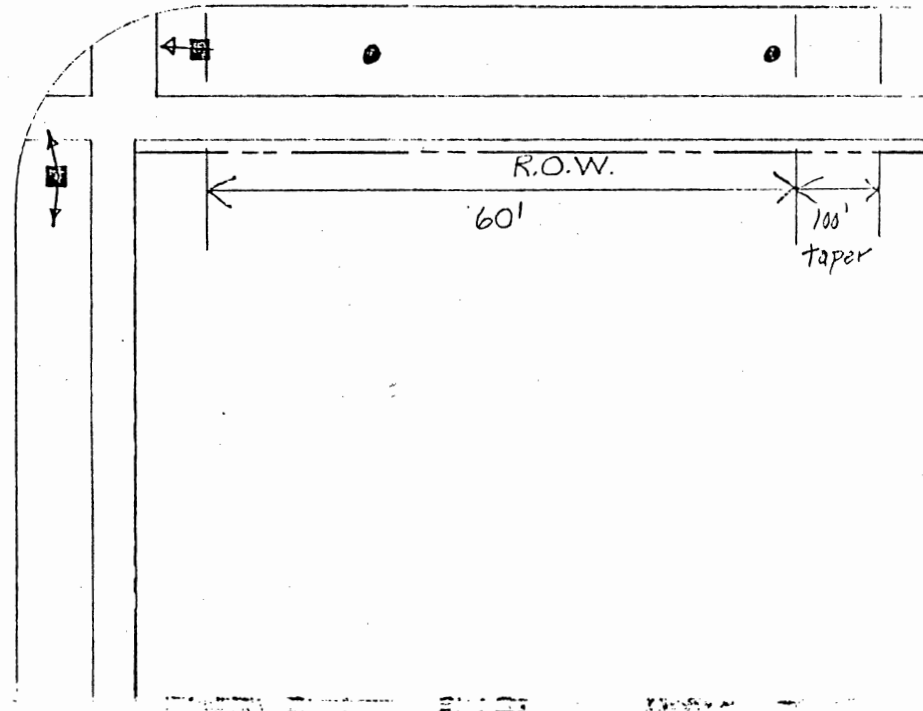
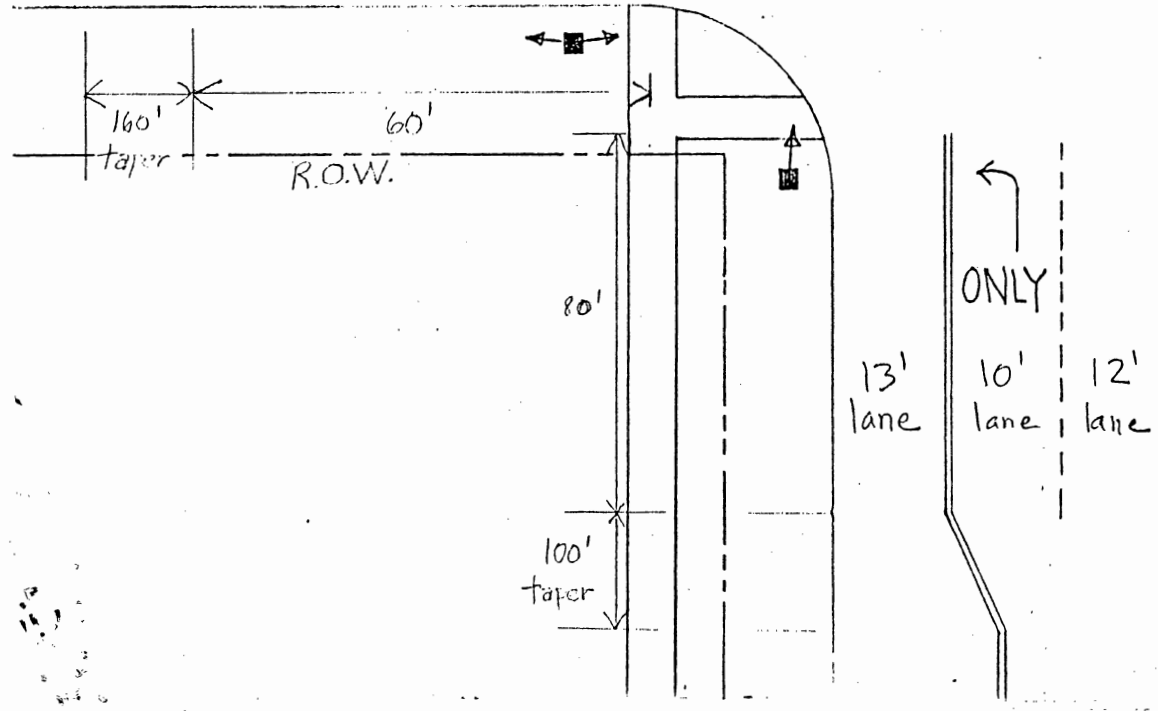
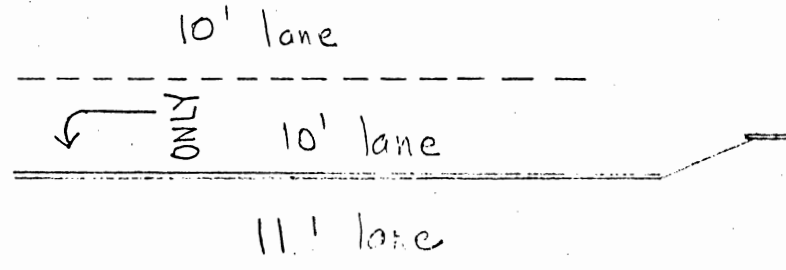
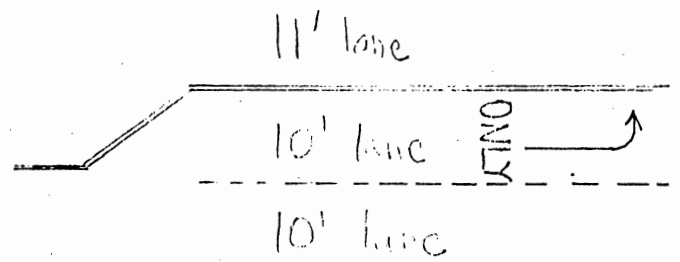
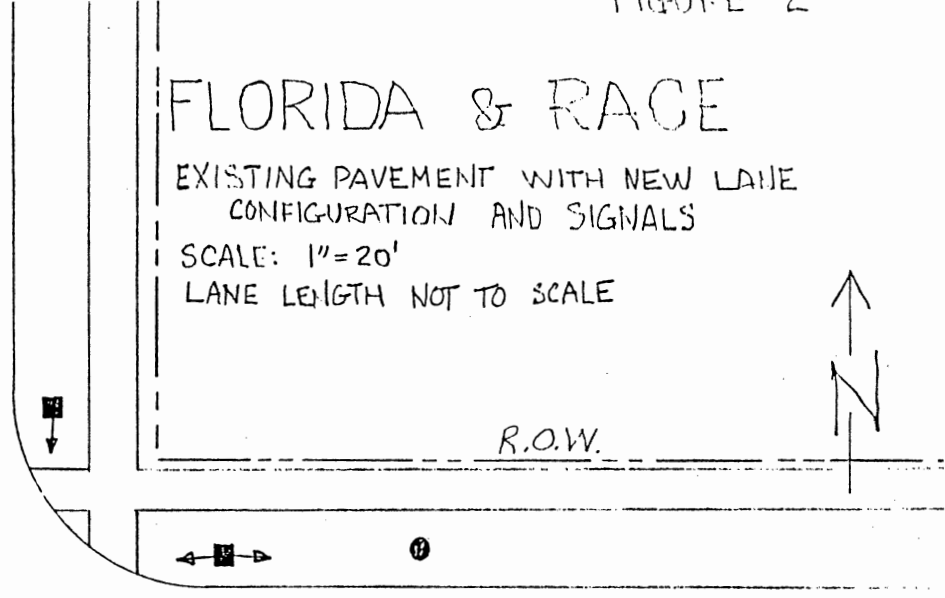
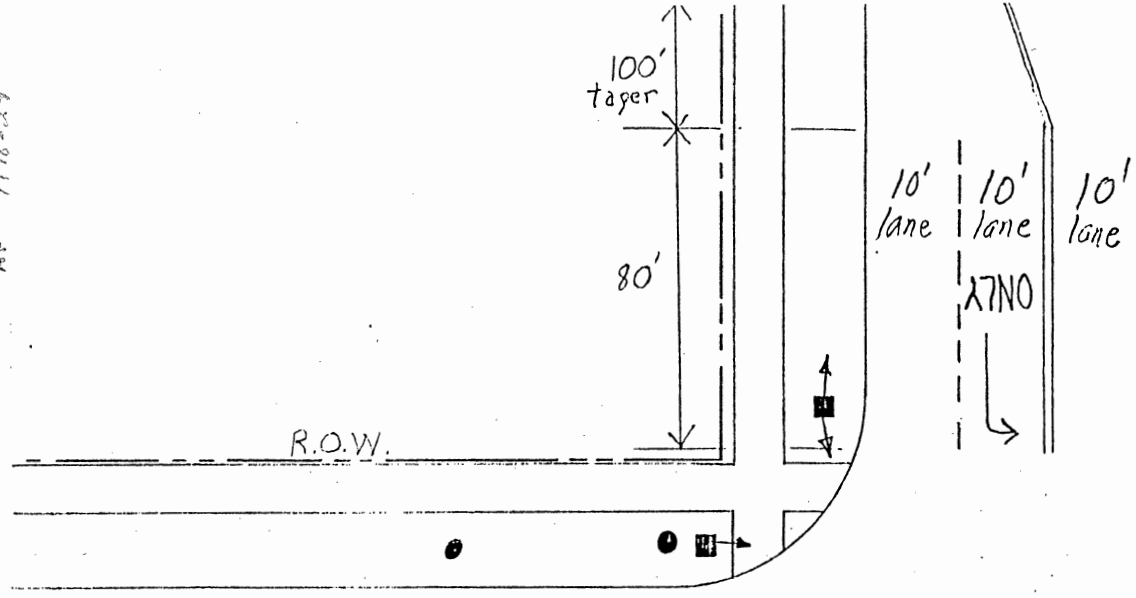

BLAIR PARK

40' taper  
100'

12' lane  
10' lane  
14' lane

L.T.N.O.

sidewalk

R.O.W.

12 lane

10' lane

10' lane

50' taper for dividing line

100'

R.O.W.

10' lane  
10' lane

FLORIDA AVE. & VINE ST.

EXISTING PAVEMENT WITH NEW LANE CONFIGURATION AND SIGNALS

SCALE: 1" = 20'

LANE LENGTH NOT TO SCALE



R.O.W.

11' lane

ONLY 11' lane

11' lane

11' lane

sidewalk

R.O.W.