



DEPARTMENT OF COMMUNITY DEVELOPMENT SERVICES

Planning Division

m e m o r a n d u m

TO: The Urbana Plan Commission
FROM: William Andresen, Planning Intern
DATE: November 30, 2018
SUBJECT: Plan Case 2358-T-18: An application by the Urbana Zoning Administrator to amend the Urbana Zoning Ordinance with changes to Article VIII (Parking and Access) to modify the requirements for handicapped parking to reflect changes in state law for handicapped parking spaces.

The Zoning Administrator requests an amendment to the Zoning Ordinance to update handicapped parking requirements. The change requested would simplify the daily administration of the Zoning Ordinance by reducing inconsistencies and updating regulations to match current State and Federal handicapped parking standards.

Background

On October 23, 2018 the Illinois Commerce Commission (ICC) accepted a revised Illinois Accessibility Code which, among other things, eliminates the requirement that all Americans with Disabilities Act (ADA) parking stalls have their own access aisle and can instead share an aisle, and also provides flexibility in the allowable widths of parking spaces and access aisles. Section VIII-3.B of the Zoning Ordinance requires that adjacent handicapped parking spaces shall not share a common access aisle, and requires handicapped parking spaces and aisles to be 8 feet wide.

Discussion

The Federal ADA standard has for some time allowed shared access aisles between handicapped parking spaces, though the Illinois Accessibility Code (IAC) did not. Now that the State has changed the IAC to match Federal standards, the Zoning Administrator seeks to amend Urbana's Zoning Ordinance to similarly match State and Federal standards. The proposed change, which would simply refer to the IAC standards, would allow for shared access drives between handicapped parking spaces, and would allow more flexible drive/aisle widths. The change will make it easier for staff to administer the Zoning Ordinance and make it easier for developers and architects to comply with the ordinance. It would also simplify the ordinance by referring directly to the IAC, so that any future changes will automatically be reflected in the Zoning Ordinance.

Options

The Plan Commission may choose to forward the amendment in whole or with specific suggested changes to City Council.

The Plan Commission has the following options for recommendation to the Urbana City Council regarding Plan Case 2358-T-18:

1. Forward this case to City Council with a recommendation to approve as presented;
2. Forward this case to City Council with a recommendation to approve as modified by specific suggested changes; or
3. Forward this case to City Council with a recommendation to deny.

Recommendation

Based on the evidence presented in the discussion above, and without the benefit of considering additional evidence that may be presented at the public hearing, staff recommends that the Plan Commission forward Plan Case No. 2358-T-18 to the Urbana City Council with a recommendation to **APPROVE**, the proposed text amendment to the Zoning Ordinance

Attachments: Exhibit A: Proposed Zoning Ordinance Changes
Exhibit B: Recent Revisions to Illinois Accessibility Code

Exhibit A

B. Handicapped Parking

1. When Illinois state, federal law, or local ordinance(s) require handicapped accessibility, all off-street parking lots, except those servicing single-family and duplex dwelling units, shall have an appropriate number of handicapped parking spaces in conformance with Table VIII-1.
2. Handicapped spaces shall be located as close as possible to an accessible building entrance.
3. Handicapped parking spaces shall be at least 16 feet wide and 18.5 feet in length and shall include an eight foot wide access aisle. Adjacent handicapped parking spaces shall not share a common access aisle.
4. 1. Handicapped parking spaces, including design and signs, must comply with the State of Illinois Accessibility Code as amended. Where the requirements in Section VIII-3.B. of the Urbana Zoning Ordinance and the State Code differ, the more restrictive of the two standards shall apply.

TABLE VIII-1. HANDICAPPED PARKING

<i>Total Number of Parking Spaces Provided</i>	<i>Number of Handicapped Parking Spaces Required</i>
1 to 20	1
21 to 50	2
51 to 75	3
76 to 100	4
101 to 150	5
151 to 200	6
201 to 300	7
301 to 400	8
401 to 500	9
501 to 1,000	2% of total number of parking spaces provided
Over 1,000	20 plus 1 for each 100 over 1,000

Exhibit B

ILLINOIS REGISTER

CAPITAL DEVELOPMENT BOARD

NOTICE OF ADOPTED RULES

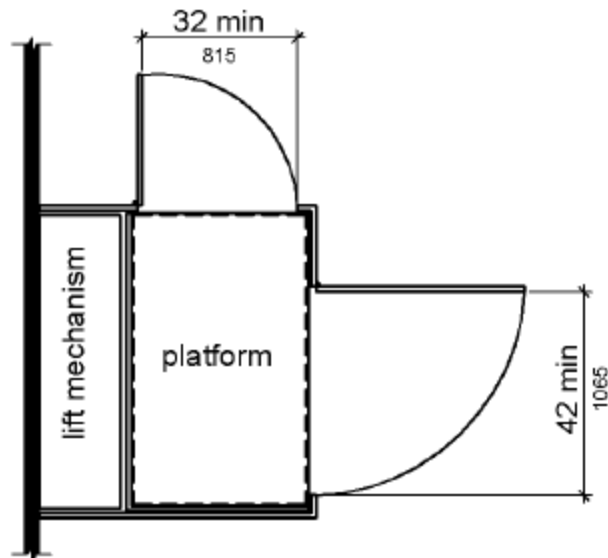

Figure 410.6 Platform Lift Doors and Gates

CHAPTER 5: GENERAL SITE AND BUILDING ELEMENTS

501 General

501.1 Scope. The provisions of Chapter 5 shall apply where required by Chapter 2 or where referenced by a requirement in this document.

502 Parking Spaces

502.1 General. *Parking spaces shall comply with 502.* Where parking spaces are marked with lines, width measurements of parking spaces and access aisles shall be made from the centerline of the markings.

EXCEPTION: Where parking spaces or access aisles are not adjacent to another parking space or access aisle, measurements shall be permitted to include the full width of the line defining the parking space or access aisle.

502.2 Vehicle Spaces. Vehicle parking spaces shall be *either 8 feet (2440 mm) wide minimum or 11 feet (3350 mm) wide minimum*, shall be marked to define the width, and shall have an adjacent access aisle complying with 502.3.

ILLINOIS REGISTER

CAPITAL DEVELOPMENT BOARD

NOTICE OF ADOPTED RULES

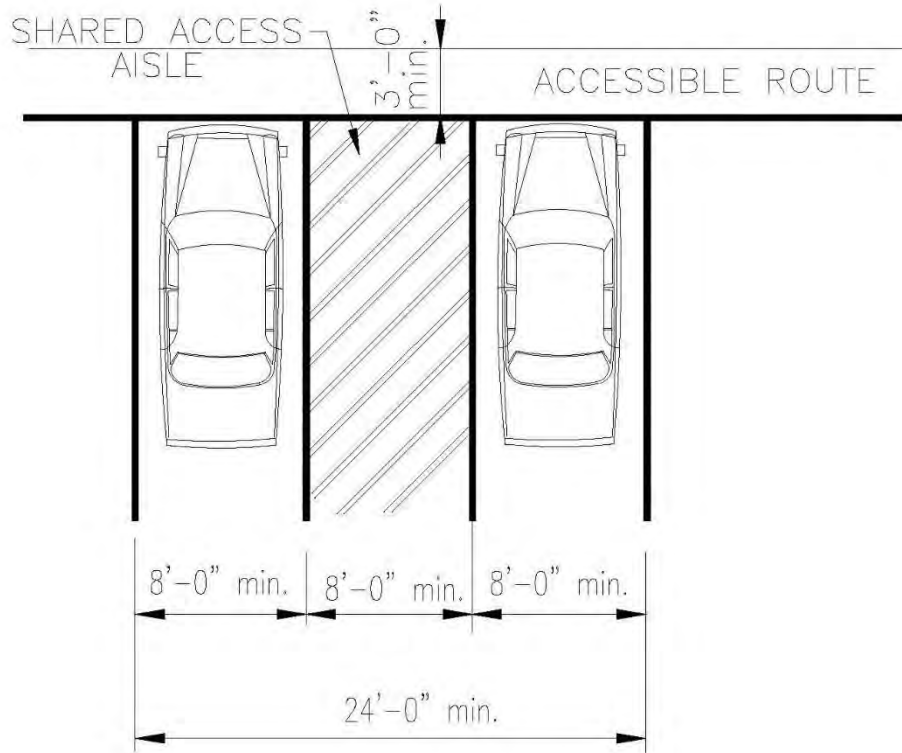

Figure 502.2 Vehicle Parking Spaces

502.3 Access Aisle. Access aisles serving parking spaces shall comply with 502.3. Access aisles shall adjoin an **accessible route**. Two parking spaces shall be permitted to share a common access aisle.

EXCEPTION: Diagonal parking spaces shall not share an access aisle. Access aisles serving diagonal accessible parking spaces shall be located on the passenger side of the vehicle space.

ILLINOIS REGISTER

CAPITAL DEVELOPMENT BOARD

NOTICE OF ADOPTED RULES

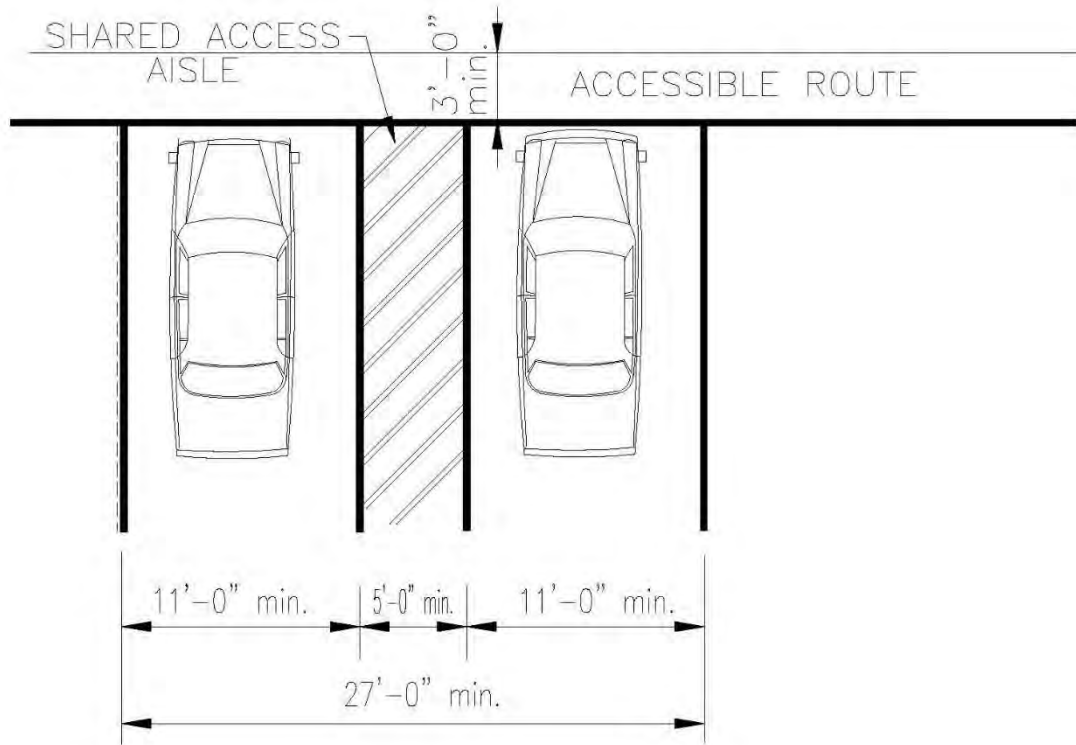
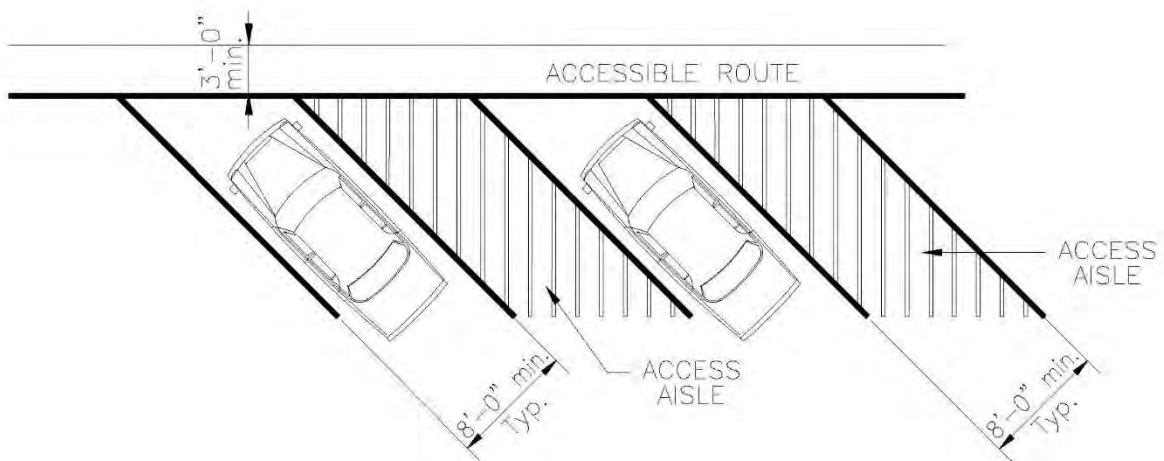

Figure 502.3 (a) Parking Space Access Aisle



(Typical Parking Spaces for 45°, 60°, and 90° Arrangements)

ILLINOIS REGISTER

CAPITAL DEVELOPMENT BOARD

NOTICE OF ADOPTED RULES

Figure 502.3 (b) Diagonal Parking Space Access Aisle

502.3.1 Width. *The combined width of an accessible parking space and its adjacent access aisle shall be 16 feet (4875 mm) minimum. Access aisles serving parking spaces that are 11 feet (3350 mm) wide minimum shall be 5 feet (1525 mm) wide minimum. Access aisles serving parking spaces that are less than 11 feet (3350 mm) wide shall be 8 feet (2440 mm) wide minimum.*

502.3.2 Length. Access aisles shall extend the full length of the parking spaces they serve.

502.3.3 Marking. Access aisles shall be marked with *diagonal striping* so as to discourage parking in them. *A high quality yellow paint recommended by the paint manufacturer for pavement striping shall be used.*

502.3.4 Location. Access aisles shall not overlap the ***vehicular way***. Access aisles shall be permitted to be placed on either side of the parking space except for angled *parking spaces required by 208.2.4* which shall have access aisles located on the passenger side of the parking spaces (see *Figure 502.3 (b)*).

502.4 Floor or Ground Surfaces. Parking spaces and access aisles serving them shall comply with 302. Access aisles shall be at the same level as the parking spaces they serve. Changes in level are not permitted.

EXCEPTION: Slopes not steeper than 1:48 shall be permitted.

502.5 Vertical Clearance. *Parking spaces required by 208.2.4, and access aisles and vehicular routes serving them, shall provide a vertical clearance of 98 inches (2490 mm) minimum.*

502.6 Identification. *Accessible parking spaces shall be designated as reserved by providing a permanently mounted R7-8 (U.S. Department of Transportation standard; see Figure 502.6 (a)) sign which contains the international symbol of accessibility. Such signs shall exhibit the dollar amount of the fine as required by the Illinois Vehicle Code [625 ILCS 5/1124 and 301.1] or the higher amount if required by local ordinance (see Figure 502.6 (b)). Signs shall be vertically mounted on a post or wall at front center of the parking space, no more than 6 feet (1830 mm) horizontally from the front of the parking space and set a minimum of 5 feet (1525 mm) and a maximum of 9 feet (2745 mm) from finished grade to the bottom of the R7-8 sign.*

Accessible Parking Signs (for parking lots subject to the ***Illinois Vehicle Code***) shall comply with the R7-8 sign shown in *Figure 502.6(a)* (U.S. Department of Transportation Standard). Existing signs may remain, but their useful lives shall not be extended by other means than normal maintenance.

ILLINOIS REGISTER

CAPITAL DEVELOPMENT BOARD

NOTICE OF ADOPTED RULES



R7-8 NO PARKING

Legend and Border—Pantone 340C

International Symbol of Accessibility—White on Pantone 286

Background

Background—White

Reduce Spacing 80%

Note:

This is a standard sign and may be ordered from any traffic sign supplier by number. The arrow may be

- Omitted if there is only one accessible space.
- Made to point in one direction.
- Replaced by a range of time such as "9 AM-5 PM" where a part-time restriction exists.

The sign must be supplemented with the Illinois Standard R7-I101 plate showing the amount of the fine for illegally parking in the reserved accessible space(s).

ILLINOIS REGISTER

CAPITAL DEVELOPMENT BOARD

NOTICE OF ADOPTED RULES

502.7 Relationship to Accessible Routes. Parking spaces and access aisles shall be designed so that *vehicles*, when parked, cannot obstruct the required clear width of adjacent *accessible routes*.

503 Passenger Loading Zones

503.1 General. Passenger loading zones shall comply with 503.

503.2 Vehicle Pull-Up Space. Passenger loading zones shall provide a vehicular pull-up space 96 inches (2440 mm) wide minimum and 20 feet (6100 mm) long minimum.

503.3 Access Aisle. Passenger loading zones shall provide access aisles complying with 503 adjacent to the vehicle pull-up space. Access aisles shall adjoin an *accessible route* and shall not overlap the *vehicular way*.

503.3.1 Width. Access aisles serving vehicle pull-up spaces shall be 60 inches (1525 mm) wide minimum.

503.3.2 Length. Access aisles shall extend the full length of the vehicle pull-up spaces they serve.

503.3.3 Marking. Access aisles shall be marked so as to discourage parking in them.

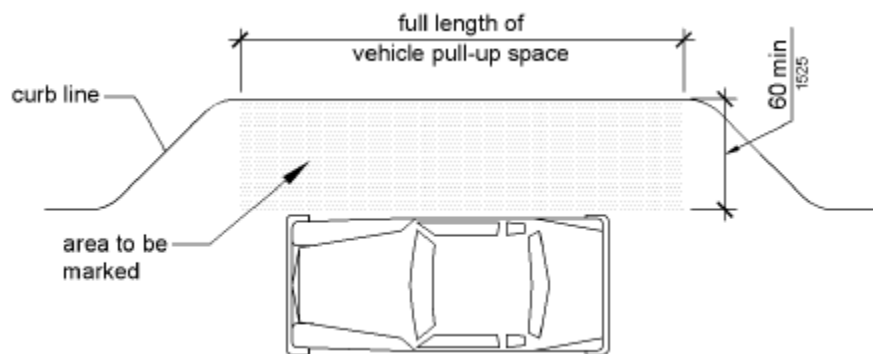

Figure 503.3 Passenger Loading Zone Access Aisle

503.4 Floor and Ground Surfaces. Vehicle pull-up spaces and access aisles serving them shall comply with 302. Access aisles shall be at the same level as the vehicle pull-up space they serve. Changes in level are not permitted.

ILLINOIS REGISTER

CAPITAL DEVELOPMENT BOARD

NOTICE OF ADOPTED RULES

EXCEPTION: Slopes not steeper than 1:48 shall be permitted.

503.5 Vertical Clearance. Vehicle pull-up spaces, access aisles serving them, and a vehicular route from an *entrance* to the passenger loading zone, and from the passenger loading zone to a vehicular exit shall provide a vertical clearance of 114 inches (2895 mm) minimum.

504 Stairways

504.1 General. Stairs shall comply with 504.

504.2 Treads and Risers. All steps on a flight of stairs shall have uniform riser heights and uniform tread depths. Risers shall be 4 inches (100 mm) high minimum and 7 inches (180 mm) high maximum. Treads shall be 11 inches (280 mm) deep minimum.

504.3 Open Risers. Open risers are not permitted.

504.4 Tread Surface. Stair treads shall comply with 302. Changes in level are not permitted.

EXCEPTION: Treads shall be permitted to have a slope not steeper than 1:48.

504.5 Nosings. The radius of curvature at the leading edge of the tread shall be 1/2 inch (13 mm) maximum. Nosings that project beyond risers shall have the underside of the leading edge curved or beveled. Risers shall be permitted to slope under the tread at an angle of 30 degrees maximum from vertical. The permitted projection of the nosing shall extend 1 1/2 inches (38 mm) maximum over the tread below.